

ET3-R Ceiling Mounted Urinal Flush Valve - TROUBLE SHOOTING:

Issue - No Water Out

- CHECK WATER AND POWER SUPPLY;
- UNPLUG ALL CABLES, LEAVE UNPLUGGED FOR 5 MINUTES (THIS GIVES THE ELECTRONICS A CHANCE TO RESET) BEFORE RECONNECTING EVERYTHING CAREFULLY;
- CHECK SENSOR PLATE HAS BEEN INSTALLED CORRECTLY AS BELOW – (SEE SENSOR INSTALLATION SECTION OF THE INSTALLATION MANUAL FOR FULL DETAILS).
- CLEAN FILTER/SOLENOID AND RE-TEST.
- IF PROBLEM PERSISTS, CONTACT US.

For Single Urinal – ensure sensor plate screws are parallel to wall:

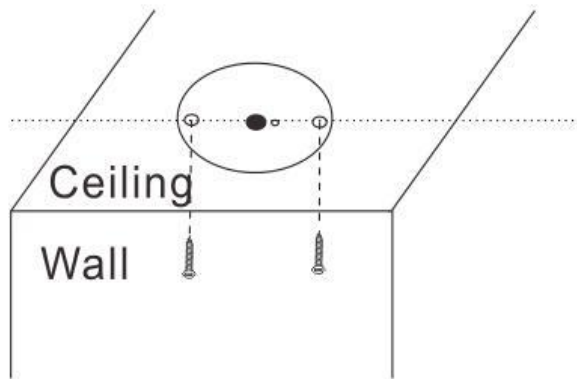

For Twin/Trough urinals – ensure sensor plate screws are aligned facing the wall:

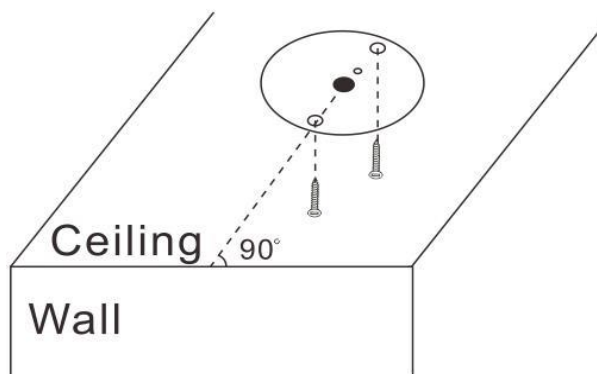

Issue – Not Enough or Too Much Water Flow

- CHECK AND ADJUST YOUR WATER PRESSURE AS APPROPRIATE – RECOMMENDED WATER PRESSURE IS 350kPA.
- FLOW VALVE MAY REQUIRE ADJUSTMENT – FLOW CAN BE ADJUSTED WITH FLOW VALVE SCREW ON SOLENOID VALVE, NEXT TO THE INLET – SEE DIAGRAM:

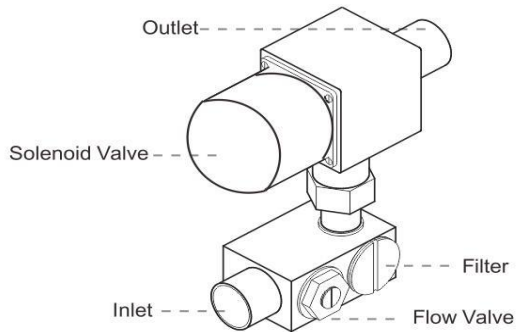

Issue – Flush Time/Sensing Distance Not Adequate

- FLUSH VALVE SETTINGS MAY REQUIRE SET-UP/ADJUSTMENT – REFER TO THE ‘SETTINGS’ AND ‘FLUSH VOLUME SETTINGS’ SECTIONS OF THE INSTALLATION MANUAL FOR FULL INSTRUCTIONS. A COPY IS AVAILABLE ON THE INSTALLATION PAGE OF OUR WEBSITE enviro-tech.com.au

For further information and advice - contact us on:
1300 530 883 or e-mail info@enviro-tech.com.au