



INSTALLATION INSTRUCTIONS

**ET3-10 URINAL FLUSH VALVE
5 Star WELS Rated**

Thank you for purchasing this Enviro-Tech product

INSTALLATION STEPS

- >Fix urinal box and face plate into wall.
- >Always flush pipe work before installation.
- >Connect water feed to inlet of valve.
- >Connect outlet to urinal.
- >Insert batteries to DC battery box.
- >Connect battery box to transformer. (If mains powered)
- >Connect transformer (battery box if DC only) to face plate.
- >Connect solenoid valve to face plate plug.
- >Connect transformer to power.

Once installation is complete test flush by activating infrared sensor, collect the flush water in measuring jug (including pre-flush), the total volume should be less than 1.0Ltr. If necessary adjust flow with flow valve adjuster by inlet.

(Note: Total flush volume of .900mls is preset at the factory using 350kPa)

TECHNICAL SPECIFICATION

Function	ET3-10
Power Input	DC:6V(4x1,5V AA alkaline battery) AC:220-240V (50/60 Hz)
Power consumption	Static:<4Ma,active:<500mA
Water Pressure	100kPa-500kPa (recommended 350kPa)
Inlet/outlet Diameter	15mm ½ G
Detection zone	750mm-800mm (Adjustable)
Confirmation time	5 seconds
Low power consumption	4 AA alkaline batteries 108,000 cycles
Flush time	4 Seconds (Adjustable)
Reset time after flush	10 seconds
Trap seal protection	Automatic flush every 24hrs if not used
Stadium mode	Pre-flush stops when in frequent use

COMPONENT - ET3-10

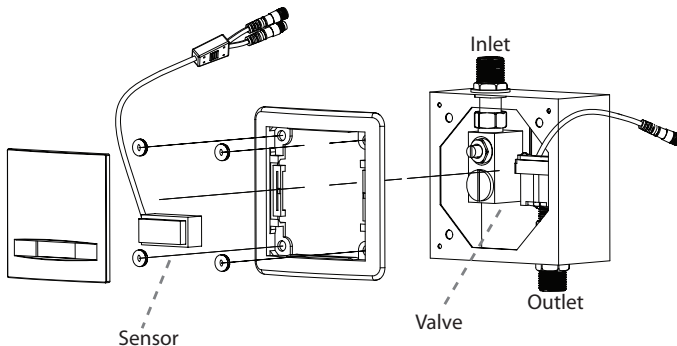

COMPONENTS

1. Solenoid Valve

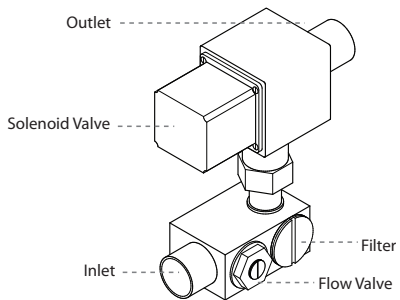

2. DC Battery box

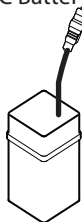

3. Transformer

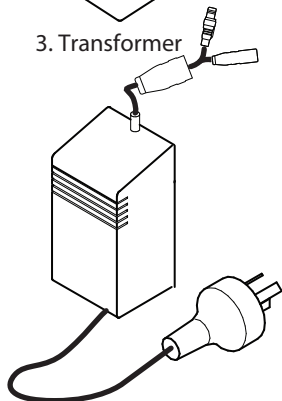

INSTALLATION - FRONT VIEW

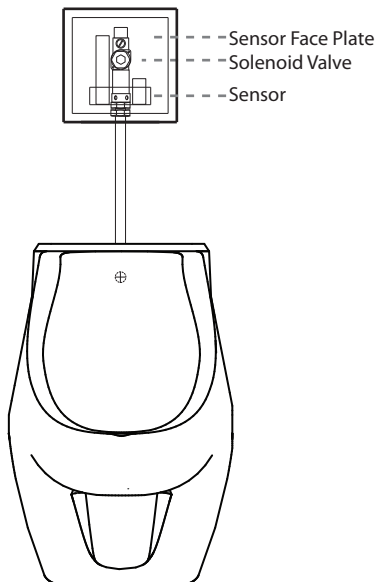

INSTALLATION - SIDE VIEW

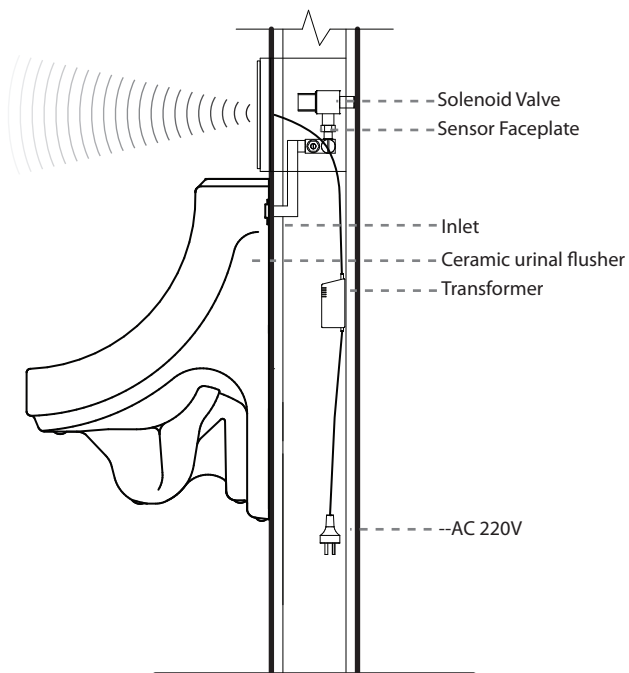

TROUBLE SHOOTING

Problem	Possible Cause	Solution
No Water	No power Water supply cut off low Water pressure Blocked filter	Check power supply and batteries are installed Check water supply Increase water pressure Clean filter
Low flush volume	Low Water pressure Low flush volume Blocked filter	Increase water pressure Adjust flow valve Clean filter
High flush volume	High flush volume High water pressure	Adjust flow valve Decrease water pressure
Continual flushing	Sensor obstructed	Clear obstruction
Indicator light off	Batteries flat Bad connection	Replace batteries Check connection

AFTERCARE

Whilst advanced plating techniques are used in the manufacture of this product, the surface will be affected if cleaned incorrectly.

Surfaces should be maintained using a clean damp cloth, no abrasive agents or materials should be used or come into contact with the surface finish, or this will invalidate your guarantee

Please contact manufacturer if required

Australia: 1300 530 883

New Zealand: 0800 2 ENVIRO

This automatic urinal flush valve is manufactured strictly to adhere to the ISO9001 standard,

WaterMark certification and WELS standards.

Enviro-tech has the right of updating the product technology.